

STONESOFT



Appliance Installation Guide

StoneGate SGI-2000

Copyright © 2001–2006 Stonesoft Corp. All rights reserved. No part of this book may be reproduced or transmitted in any form or by any means, electronic or mechanical, including photocopying, recording, or by any information storage and retrieval system, without permission in writing from Stonesoft Corporation.

Stonesoft Corporation
Itälahdenkatu 22 A
FI-00210 Helsinki
Finland

Stonesoft Inc.
1050 Crown Pointe Parkway,
Suite 900
Atlanta, GA 30338 USA

Trademarks and Patents

The products described in this documentation are protected by U.S. Patents and European Patents: U.S. Patents no. 6,650,621, 6,856,621, 6,912,200, and 6,996,573; European patents no. 1065844, 1259028, 1289183, 1289202, 1326393, 1361724, and 1379037; and may be protected by other US patents, foreign patents, or pending applications.

Stonesoft, the Stonesoft logo, StoneBeat, FullCluster, ServerCluster, StoneGate, and WebCluster are trademarks or registered trademarks of Stonesoft Corporation in the United States and/or other countries. Multi-Link technology, Multi-Link VPN, and the StoneGate clustering technology as well as other technologies included in StoneGate are protected by patents or pending patent applications in the U.S. and other countries.

Sun, Sun Microsystems, Solaris, and Java are trademarks or registered trademarks of Sun Microsystems, Inc. in the United States and other countries. Windows and Microsoft are trademarks or registered trademarks of Microsoft Corporation in the United States and/or other countries. Linux is a registered trademark of Linus Torvalds.

All other trademarks or registered trademarks are property of their respective owners.

Disclaimer

Although every precaution has been taken to prepare these materials, Stonesoft assumes no responsibility for errors, omissions, or resulting damages from the use of the information contained herein. All IP addresses in these materials were chosen at random and are used for illustrative purposes only. They are not intended to represent the IP addresses of any specific individual or organization.

THESE MATERIALS ARE PROVIDED "AS-IS." STONESOFT MAKES NO WARRANTIES, EXPRESS OR IMPLIED, AS TO, THE INFORMATION CONTAINED HEREIN. IN ADDITION, STONESOFT MAKES NO EXPRESS OR IMPLIED WARRANTIES OF MERCHANTABILITY OR FITNESS FOR A PARTICULAR PURPOSE OR USE WITH RESPECT THE INFORMATION OR TECHNIQUES CONTAINED IN THESE MATERIALS. IN NO EVENT SHALL STONESOFT BE LIABLE FOR ANY INDIRECT, SPECIAL, CONSEQUENTIAL OR INCIDENTAL DAMAGES, INCLUDING, BUT NOT LIMITED TO, LOST PROFITS OR LOSS OR DAMAGE TO DATA ARISING FROM THE USE OF THESE MATERIALS, EVEN IF ADVISED IN ADVANCE OF THE POSSIBILITY OF SUCH DAMAGES.

Revision: SGAIG_I2000_051906M

Introduction

Thank you for choosing Stonesoft's StoneGate appliance. This guide provides instructions for the initial hardware installation and the maintenance of the SGI-2000 appliances.

You must have a working Management Center on a separate server to bring the appliance(s) operational. The system architecture is explained on the next page. See the *StoneGate IPS Installation Guide* for details.

Contents

Getting Started	4
Safety Precautions	6
Front Panel	8
Unpacking the Appliance	9
Rack-Mounting	9
Connecting the Cables	14
Initial Configuration	16



Caution – Never open the covers of the appliance! There are no user serviceable parts inside. Opening the covers may lead to serious injury and will void the warranty. Read the [Safety Precautions](#), on page 6 before you conduct any installation or maintenance operations on the appliance.

Getting Started

StoneGate System Components

Illustration 1 StoneGate Components

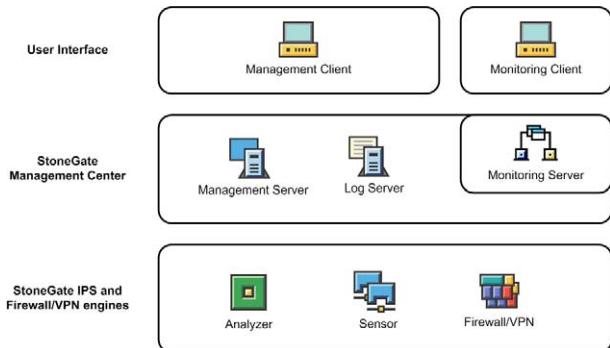

The illustration above shows all available StoneGate components. Out of these, you need the following components to have an operational IPS system:

1. A **Management Server**, which stores the configuration of the system. In most environments, it is best to have just one common Management Server for all firewall and IPS engines.
2. At least one **Log Server** to handle and store logs and alerts (can be installed simultaneously on the same machine with the Management Server).
3. At least one **Management Client** that you use to connect to the Management Server to change settings and monitor the system.
4. The **IPS Engines** that handle the actual traffic processing. In this case, the engines are your StoneGate appliance(s).
5. **Licenses** for each component except the Management Client(s).

The **Monitoring Server** and the **Monitoring Client** are optional components that are available on separate order.

StoneGate firewall engines can be added to the same system for unified management and incident handling.

Installation Procedure

The appliance installation involves the following mandatory steps:

1. Configure the IPS elements in the Management Center (see the separate *StoneGate Installation Guide* or the online help of the Management Client).
2. Save the initial configuration to receive a one-time password for establishing trust between the appliance and the Management Server (see the separate *StoneGate Installation Guide*).
3. Install the appliance into a rack and connect the cables as instructed in this guide.
4. Perform the initial configuration and establish contact between the appliance and the Management Server (see *Initial Configuration*, on page 16).

Product Documentation

The following documentation covers the StoneGate IPS products:

- The *IPS Installation Guide* explains how to install the Management Center and configure your IPS engines' basic settings.
- The *online help system* of the Management Client contains the step-by-step instructions for the daily configuration and management of your system.
- The *Administrator's Guide* contains the same information as the online help system, but in PDF form.
- The *IPS Reference Guide* contains background and reference information that helps you to plan and understand your system.

Finding the Documentation

Press F1 while in any Management Client window to view the online help.

All PDF guides are available:

- On the Management Center CD-ROM (in the Documentation folder)
- At the Stonesoft Website at my.stonesoft.com/download/doc

The *Installation Guide* and *Reference Guide* are delivered as printed books if so requested in your order.

Install the free Adobe Reader program to view the PDF documents (available at www.adobe.com/reader/).

Safety Precautions

The following safety information and procedures should be followed whenever working with electronic equipment. However, please be advised that StoneGate Appliances are not end-user serviceable, and you should never open the appliance chassis for any reason. Doing so will void any hardware warranty that may be associated with your appliance.

Electrical Safety Precautions

Basic electrical safety precautions should be followed to protect yourself from harm and the appliance from damage:

- Be aware of the locations of the power on/off switch as well as the room's emergency power-off switch, disconnection switch, or electrical outlet. If an electrical accident occurs, you can then quickly cut power to the system.
- Do not work alone when working with high voltage components.
- Use only one hand when working with powered-on electrical equipment. This is to avoid making a complete circuit, which will cause electrical shock. Use extreme caution when using metal tools, which can easily damage any electrical components or circuit boards they come into contact with.
- Do not use mats designed to decrease electrostatic discharge as protection from electrical shock. Instead, use rubber mats that have been specifically designed as electrical insulators.
- The power supply cord must include a grounding plug and must be plugged into a grounded electrical outlet.



Caution – Never open the appliance chassis! There are no user serviceable parts inside. The chassis must be in place to ensure proper cooling. Opening the chassis will also void your warranty.

General Safety Precautions

Follow these rules to ensure general safety:

- Keep the area around the appliance clean and free of clutter.
- The appliance weighs approximately 33 kg (72 lbs.) when fully loaded. When lifting the system, two people at either end should lift

slowly with their feet spread out to distribute the weight. Always keep your back straight and lift with your legs.

- We recommend using a regulating uninterruptible power supply (UPS) to protect the device from power surges, voltage spikes and to keep your system operating in case of a power failure.

ESD Precautions

Electrostatic discharge (ESD) is generated by two objects with different electrical charges coming into contact with each other. An electrical discharge is created to neutralize this difference, which can damage electronic components and printed circuit boards. Use a grounded wrist strap designed to prevent static discharge.

Note – Use a UPS (Uninterruptible Power Supply) in critical environments with your StoneGate appliance. If after a brief power outage your StoneGate appliance only partially starts up (for example, the power light is on, but the NIC LEDs are off and the appliance does not connect) turn the appliance off for five seconds and then back on.

Operating Precautions

Care must be taken to assure that the chassis cover is in place when the appliance is operating to ensure proper cooling. Out of warranty damage to the appliance system can occur if this practice is not strictly followed.

Front Panel

Illustration 2 SGI-2000 Control panel

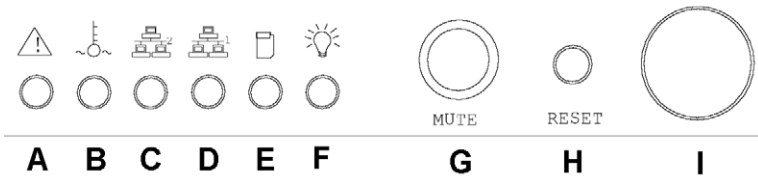

TABLE 14.1 Control panel LEDs

A	Power failure on one or more failed power modules
B	Overheat
C	LAN2 Ethernet interface
D	LAN1 Ethernet interface
E	Hard drive activity
F	Power indicator

TABLE 14.2 Control panel buttons

G	Chassis alarm reset: reactivates the chassis alarm function after an alarm.
H	Reset: reboots the system.
I	Power: turns power on/off.

Unpacking the Appliance

Inspect the box the appliance was shipped in and note if it was damaged in any way. If the device itself shows damage, file a damage claim with the carrier who delivered it. Confirm that the Stonesoft anti-tamper tape on the chassis is intact.

Rack-Mounting



Caution – Never open the appliance chassis! There are no user serviceable parts inside. The chassis must be in place to ensure proper cooling. Opening the chassis will also void your warranty.

Preparing for Rack-Mounting

The appliance delivery includes the rail assemblies and the mounting screws you need to install the system into the rack.



Caution – Read the sections below before you begin the installation.

Selecting a location

Decide on a suitable location for the rack unit that will hold the appliance:

- The appliance must be situated in a clean, dust-free area that is well ventilated.
- Avoid areas where heat, electrical noise and electromagnetic fields are generated.
- Leave enough clearance in front of the rack to enable you to open the front door completely (~63 cm/25 inches).
- Leave enough clearance in the back of the rack to allow for sufficient airflow and ease in servicing (~76 cm/30 inches).

Rack precautions

- Ensure that the leveling jacks on the bottom of the rack are fully extended to the floor with the full weight of the rack resting on them.
- In single rack installation, attach stabilizers to the rack.
- In multiple rack installations, couple the racks together.
- Always make sure the rack is stable before extending a component from the rack.

- Extend only one component at a time—extending two or more simultaneously may cause the rack to become unstable.

Device precautions

- Review the electrical and general safety precautions in [Safety Precautions](#), on page 6.
- Determine the placement of each component in the rack before you install the rails.
- Install the heaviest device components on the bottom of the rack first, and then work up.
- The appliance must be connected to a grounded power outlet.
- Use a regulating uninterruptible power supply (UPS) to protect the device from power surges, voltage spikes and to keep your system operating in case of a power failure.
- Always keep the rack's front door and all panels and components on the devices closed when not servicing to maintain proper cooling.

Installing the Appliance into a Rack

Follow the instructions in this section and the precautions laid out in the previous sections above to install the StoneGate appliance into a rack. Please also refer to the documentation that came with the rack.

The appliance package includes one pair of rack rail assemblies. Each of these assemblies consist of two sections: the inner chassis rail that secures to the appliance (see [Illustration 3](#)) and the outer rack rail that secures directly to the rack. You must detach the inner rail before installing.

▼ To remove the inner rails

Illustration 3 Rack rail assembly

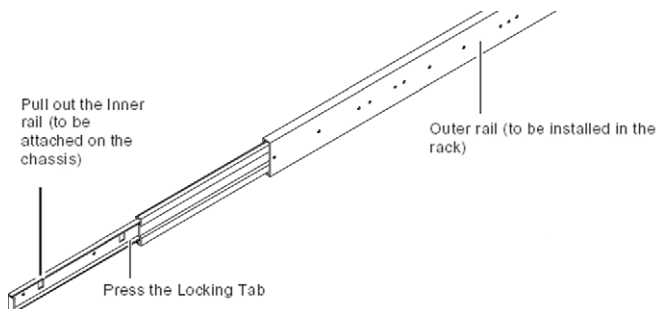

1. Pull the inner rail out as far as possible in the rail assembly.
2. Press the locking tab to release the rail and remove the rail from the assembly. Do this for both the left and right side rail assemblies.

▼ To attach the inner rails to the appliance

Illustration 4 Install the chassis rails

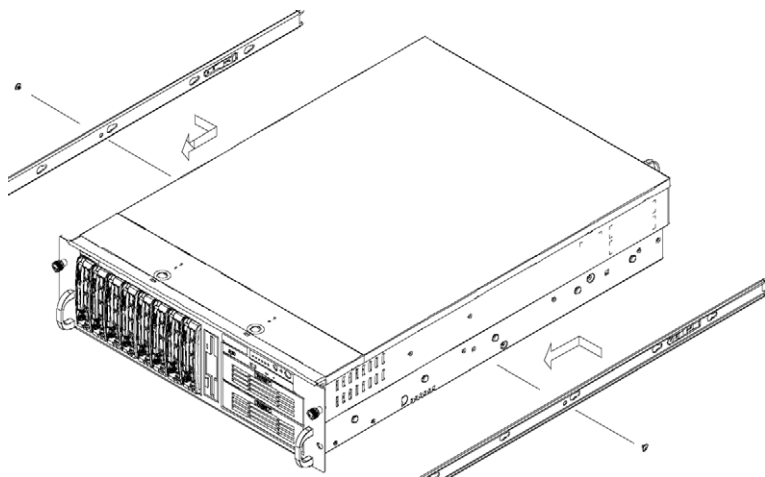

1. Locate the five rail buttons on each side of the appliance and the five corresponding holes on the inner rails.
2. Align the larger end of each hole against its corresponding button. Once all are aligned, push the holes toward their corresponding buttons.

Illustration 5 Securing the inner rails with screws

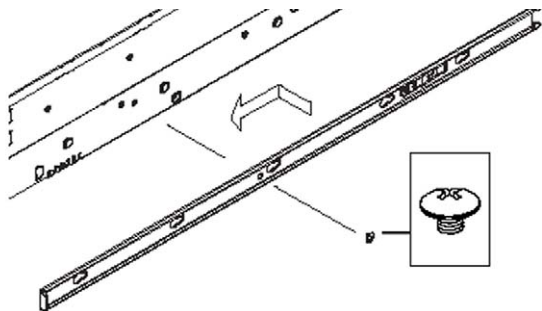

3. Once the rail is placed on the appliance, pull the rail toward the front of the appliance until the rail buttons lock in the small ends of the corresponding holes.
4. Secure the rail to the appliance with a screw (see [Illustration 5](#)). Repeat the above steps to install other rail on the appliance.

After you have installed the inner rails on the chassis, you are ready to install the outer rails of rail assemblies to the rack.

▼ To attach the outer rails to the rack

1. Find two pairs of front and rear rack brackets in the package. The short front brackets are marked with “up/front” arrows and the long rear brackets with “up/rear” arrows.

Illustration 6 Securing the brackets to the outer rails

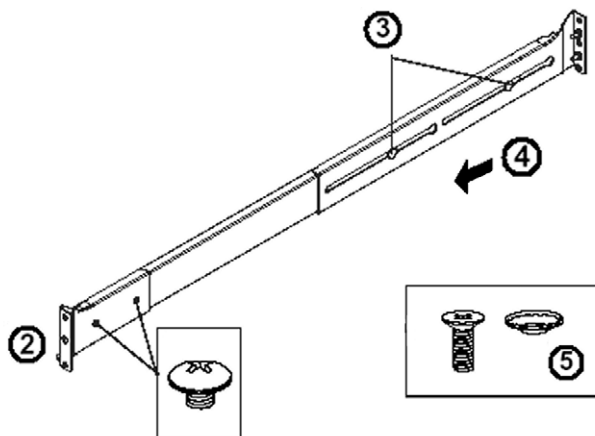

2. Secure the short front bracket to the outer rail (see [Illustration 6](#)).
3. Attach the long rear bracket by sliding it on the rail.
4. Measure the depth of your rack and adjust the length of the rails accordingly. Repeat the same steps install the other outer rail on the chassis.
5. Secure the outer rack rails to the rack using screws and washers.

▼ To install the appliance into the rack

1. Slide the appliance with the inner rails into the outer rails attached to the rack. You may have to press the locking tabs when inserting. When the appliance has been pushed completely into the rack, you should hear the locking tabs “click” as the rails lock.
2. Finish by inserting and tightening the thumbscrews that hold the front of the appliance to the rack.

Connecting the Cables

Connect the cables after installing the appliance into the rack, see [Illustration 7](#).

Illustration 7 Back Panel of SG-2000

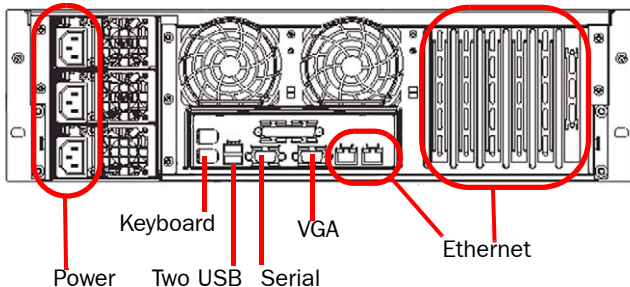

1. Connect the monitor cable to the VGA port and the keyboard to the keyboard port and/or connect the serial cable.
2. Connect the power cord(s) to the AC power connector(s).

Illustration 8 Network Interfaces

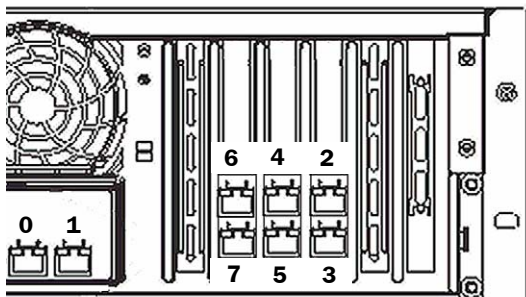

3. Connect network cables to the Ethernet ports. The network interface numbers (eth 0 to eth 7) used in the appliance configuration wizard are shown in [Illustration 8](#).
 - The interfaces eth 2/eth 3, eth 4/eth 5 and eth 6/eth 7 are bypass pairs for use as inline interfaces (for example, if traffic enters through interface 2, it exits through interface 3). Plug in the network cables accordingly.

Connecting the Appliance to the Power Supply

Plug the power cord into a grounded, high-quality power strip that offers protection from electrical noise and power surges. We highly recommend using an uninterruptible power supply (UPS) to ensure continuous operation and minimize the risk of damage to the appliance in case of sudden loss of power.

Initial Configuration

Your StoneGate appliance comes pre-loaded with StoneGate engine software. However, before a security policy can be loaded on the appliance, you must configure the engine software. To successfully complete the configuration:

- The Sensor, Analyzer, or Sensor-Analyzer element must be defined in the Management Center
- You must have created a one-time password for this engine. See the *StoneGate Installation Guide* for details.

Note – The appliance must contact the Management Server before it can be operational.

▼ To start the appliance

1. Make sure you have a physical connection to the appliance using a monitor and keyboard or a serial cable (see [Connecting the Cables](#), on page 14).
 - When using a serial line console, use the terminal settings 9600bps, 8 databits, 1 stopbit, no parity.
2. Turn on the power using the power on/off button. The engine bootup process is shown in the console and the engine configuration wizard starts.
 - The engine configuration wizard can be started at any time on the engine command line using the `sg-reconfigure` command.

Configuring the Engine

▼ To select the configuration method

Illustration 9 Welcome

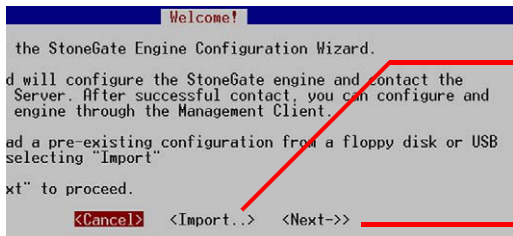

To import a saved configuration, highlight **Import** using the arrow keys and press ENTER.

To skip the import, highlight **Next** and press ENTER.

▼ To set the keyboard layout

Illustration 10 Configure OS Settings

Highlight the entry field for **Keyboard Layout** using the arrow keys and press ENTER. The Select Keyboard Layout dialog opens.



Illustration 11 Select Keyboard Layout

Highlight the correct layout and press ENTER.

Tip: Type in the first letter to move forward more quickly.



Note – If the desired keyboard layout is not available, use the best-matching available layout, or select US_English.

▼ To set the engine's timezone

Illustration 12 Configure OS Settings

1. Highlight the entry field for **Local Timezone** using the arrow keys and press ENTER.
2. Select the correct timezone in the dialog that opens.



Note – The timezone setting affects only the way the time is displayed on the engine command line. The actual operation always uses UTC time.

Note – The appliance's clock is automatically synchronized with the Management Server clock.

▼ To set the rest of the OS settings

Illustration 13 Configure OS Settings

1. Type in the name of the engine.
2. Type in the password for the user `root`. This is the only account for engine command line access.
3. Highlight **Enable SSH Daemon** and press the spacebar on your keyboard to select the option and allow remote access to engine command line using SSH.

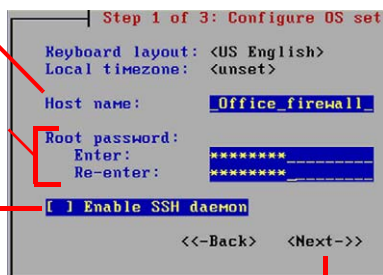

4. Highlight **Next** and press ENTER. The Configure Network Interfaces window is displayed.

Configuring the Network Interfaces

The configuration utility can automatically detect which network cards are in use. You can also add interfaces manually, if necessary.

▼ To add the network interfaces

Illustration 14 Configure Network Interfaces



Highlight **Autodetect** and press ENTER.

Check that the autodetected drivers are correct and that all interfaces have been detected. To add interfaces manually, click **Add** and select a device driver.

▼ To map the physical interfaces to Interface IDs

Illustration 15 Assigning Network Interfaces

1. Type in the NIC IDs to define how physical interfaces are mapped to the Interface IDs you defined in the engine element.

Id	Name	Driver	Link	Media	Mgmt
0	eth0	e1000	ok	<Auto/10/HD>	<Sniff> (*)
1	eth1	e1000	down	<Auto>	<Sniff> ()
2	eth2	e1000	ok	<Auto/10/HD>	<Sniff> ()

2. Highlight and press ENTER to match the speed/duplex settings to those used in each network.
3. Highlight the **Mgmt** column and press the spacebar on your keyboard to select the correct interface for contact with the Management Server.

Note – The Management interface must be the same that is configured as the Primary Control Interface for the corresponding engine element in the Management Center.

Highlight **Next** and press ENTER to continue.

Contacting the Management Server

The Prepare for Management Contact window opens. If the initial configuration was imported, most of this information is filled in.

This task has three parts. First, you activate an initial configuration on the engine. The initial configuration contains the information that the engine needs to connect to the Management Server for the first time. The initial configuration is replaced with a working configuration when you install an IPS Policy on this engine using the Management Client.

▼ To activate the Initial Configuration

Illustration 16 Prepare for Management Contact - Upper part

1. Highlight **Switch Node to Initial Configuration** and press spacebar to activate.



```
Step 3 of 3: Prepare for management contact
Enter data for switching to the initial configuration at
the management server. Applicable fields marked with *
[ ] Switch firewall node to initial configuration
[ ] Obtain node IP address from a DHCP server
[*] Enter node IP address manually
   IP address:*          192.168.10.21
   Netmask:*            255.255.255.0
   Gateway to management:
[ ] Use VLAN, Identifier: _____
```

2. Fill in according to your environment. The information must match to what you defined for the engine element (Primary Control IP Address). If the engine and the Management Server are on the same network, you can leave the **Gateway to management** field empty.

The initial configuration does not contain any working IPS policy. You must install an IPS policy on the engine to make it operational.

▼ To fill in the Management Server information

In the second part of the configuration, you define the information needed for establishing a trust relationship between the engine and the Management Server.

If you do not have a one-time password for this engine, see the *Installation Guide* for instructions on how to save an initial configuration.

Illustration 17 Prepare for Management Contact - Middle Part

1. Highlight **Contact Management Server** and press spacebar to select

2. Fill in the Management Server IP address and the one-time password that was created for this engine when you saved the initial configuration.



```
[*] Contact management server
Management server
   IP address:*          192.168.10.200
   One-time password:*   Kq53rnF8mP_
   Key fingerprint: _____
```

3. (Optional) Fill in the Key fingerprint (also shown when you saved the initial configuration). This increases the communications' security.

Note – Once initial contact has been made, the engine receives a certificate from the Management Center for identification. If the certificate is later on deleted or expires, you must repeat the initial contact using a new one-time password.

In the third part of the configuration, you select whether you want this engine to work as a Sensor, an Analyzer, or a combined Sensor-Analyzer. The selection you make must correspond to the element you created for this engine in the Management Client.

Illustration 18 Prepare for Management Contact - Lower Part

Select the type of engine using the arrow keys and the spacebar.



```
(*) Install Sensor
( ) Install Analyzer
( ) Install Combo (sensor+analyzer)

<<-Back <Finish>
```

Highlight **Finish** and press ENTER.

The engine now tries to make initial Management Server contact.

- If you see a “connection refused” error message, ensure that the one-time password is correct and the Management Server IP address is reachable from the node. Save a new initial configuration if unsure about the password.

After Successful Management Server Contact

After you see a notification that Management Server contact has succeeded, the IPS engine installation is complete and the engine is ready to receive a policy. In a while, the engine element’s status changes in the Management Client from **Unknown** to **No Policy Installed**, and the connection state is **Connected** indicating that the Management Server can connect to the node.

The next step is installing a security policy on the engine. Please see the *IPS Installation Guide* for basic instructions or the online help system of the Management Client for detailed instructions.



Caution – When using the command prompt, use the `reboot` command to reboot and `halt` command to shut down the node. Do not use the `init` command. You can also reboot the node using the Management Client.

Stonesoft Experience

Stonesoft Corporation (HEX: SFT1V) is an innovative provider of integrated network security and business continuity. Stonesoft is a global company focused on enterprise level customers requiring advanced network security and always-on business connectivity with low TCO, best price-to-performance ratio, and highest ROI.

StoneGate™ Security Platform unifies firewall, VPN and IPS, blending network security, end-to-end availability and award-winning load balancing into a unified and centrally managed system for distributed enterprises.

Founded in 1990, Stonesoft Corporation has corporate headquarters in Helsinki, Finland; Americas headquarters in Atlanta, Georgia; and Asia Pacific headquarters in Singapore.

The logo for Stonesoft, consisting of the word "STONESOFT" in a bold, blue, sans-serif font.

Stonesoft Corp.
Itälähdenkatu 22 A
00210 Helsinki
Finland
tel. +358 9 4767 11
fax. +358 9 4767 1234

Stonesoft Inc.
1050 Crown Pointe Parkway
Suite 900
Atlanta, GA 30338, USA
tel. +1 770 6681 125
fax. +1 770 6681 131

Stonesoft Corp.
90 Cecil Street
#13-01 Carlton Building
Singapore 069531
tel. +65 6325 1390
fax. +65 6325 1399